

INSTALLATION INSTRUCTIONS COVER SKIRTING

ORAC[®]
DECOR

INSTALLATIE VAN OVERZETPLINTEN | INSTALLATION DES SURPLINTHES | INSTALLATION
VON ABDECK-SOCKELLEISTEN | INSTALACIÓN CUBRE RODAPIÉ | ISTRUZIONI PER
L'INSTALLAZIONE COPRIBATTISCOPA | ИНСТРУКЦИЯ ПО НАКЛАДНОЙ ПЛИНТУС

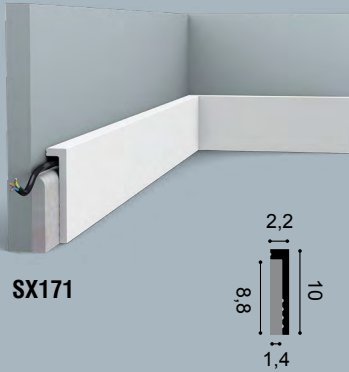

SX171

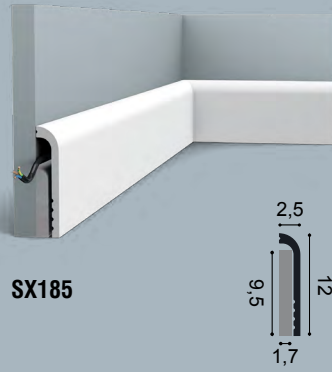

SX185



SX186



WWW.ORACDECOR.COM
>> INSTALLATION

UM343 - 06/2023

1

Ready?

ATMOSPHERE



Storage and installation conditions: Store profiles and adhesives at room temperature and wait 24 hours before installing.
Opslag- en plaatsingsvoorwaarden: Plaats profielen en lijmen 24 uur vóór de installatie op kamertemperatuur.
Conditions d'installation et de stockage: Stockez les profils et les colles à température ambiante 24 heures avant la pose.
Lager- und Installationsbedingungen: Profile und Kleber 24 Stunden vor Verlegung bei Zimmertemperatur lagern.
Condiciones de almacenamiento y de instalación: Colocar molduras y adhesivos en el lugar 24 horas antes de la aplicación.
Condizioni di stoccaggio e di installazione: conservare profili e adesivi a temperatura ambiente e attendere 24 ore prima dell'installazione.
Обязательно оставьте стеновые панели и клей на 24 часа перед монтажом в помещении под отделку.

Ready? Set? Go!

✓ **INSTALLATION
GUARANTEE**

SURFACE



Dust free
Stofvrij
Sans poussière
Staubfrei
Libre de polvo
Privi di polvere
Удалите пыль



Sand and wash surface
Schoor en reinig de ondergrond
Poncez et nettoyez la surface
Schleifen und reinigen Sie den Untergrund
Superficie lisa y limpia
Superficie carteggiata e pulita
Очистите поверхность



Flat wall & ceilings
Vlakke wand en plafond
Mur et plafond plats
Plane Wand und Decke
Paredes y techos lisos
Pareti e soffitti
Выровняйте стены и потолок



Dry
Droog
Sec
Trocken
Seco
Asciutto
Высушите



No grease
Vetvrij
Sans graisse
Fettfrei
Sin grasa
Assenza di grasso
Обезжирьте

2

Set?

DECOFIX ADHESIVES



Online glue calculator
Online lijmcalculator
Calculateur de colle en ligne
Online Klebrechner
Calculadora de adhesivos online
Calcolatore di colla online
Калькулятор клея



Interior, porous and dry surface
Binnen, poreuze en droge ondergronden
Pose à l'intérieur, surfaces poreuses, pièces non humides
Innen, poröse/saugfähig, und trockene Untergründe
Interior, superficies porosas y secas
Superficie interna, porosa e asciutta
Для внутренних работ, пористых и сухих поверхностей



Heavy profiles
Zware lijsten
Grandes moulures
Grosse Profilen
Perfiles pesados
Profilii pesanti
Тяжёлые профили

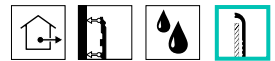

Exterior, non-porous or humid surface
Buiten, niet-poreuze of vochtige ondergronden
Pose à l'extérieur, surfaces non poreuses ou environnement humide
Außen, nicht-poröser/saugfähige Untergrund oder Feuchträume
Exterior, superficies non porosas o ambientes húmedos
Superficie esterna non porosa o umida
Для внешних работ, непористых или влажных профилей



Seal wall/ceiling

Verbinding muur/plafond
Collage mur/plafond
Verbindung Wand/Decke
Adherencia techos/paredes
Collante per parete/soffitto
Стены/потолки

DecoFix Pro

Strong, water-based acrylic installation adhesive

FDP500 310 ml > 7 - 8 m
10.5 oz > 23 - 26 ft
FDP600 4200 ml > 65 - 110 m
142 oz > 213 - 361 ft



or
ou
oder
o
oppure
или



DecoFix Power

Very strong MS-Polymer-based installation adhesive

FDP700 290 ml > 7 - 8 m
9.8 oz > 23 - 26 ft

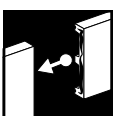

Joints between mouldings

Verbinding tussen profielen
Joints entre les profils
Nahtverbindungen zwischen Profilen
Uniones de los perfiles
Giunte tra i profili
Стыки между профилями



DecoFix Ultra

Polymer-based white adhesive

FX400 270 ml > min. 80 m
9.13 oz > min. 262 ft

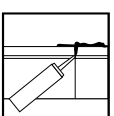

Finish seams with DecoFiller

Werk naden af met DecoFiller
Finissez les coutures avec DecoFiller
Nähte mit DecoFiller versiegeln
Acabar las costuras con DecoFiller
Rifinire le giunte con DecoFiller
Заделайте все швы с помощью DecoFiller



DecoFiller

Ready to use lightweight acrylic filler

FL300 310 ml > 30 m
10.5 oz > 98 ft



Please note the maximum dimensions of the old skirting board!

Let op de maximale afmetingen van de oude plint! | Veuillez tenir compte des dimensions maximales de l'ancienne plinthe ! | Bitte beachten Sie die maximalen Abmessungen der alten Sockelleiste! | Tenga en cuenta las dimensiones máximas del antiguo zócalo | Tenete conto delle dimensioni massime del vecchio battiscopa! | Обратите внимание на максимальные размеры старого плинтуса!

SX171

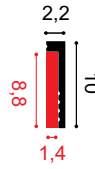

SX185

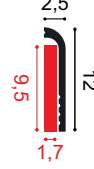

SX186

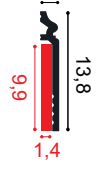

3

Go!
INSTALLATION

Also see general instructions for mounting | Zie ook de algemene instructies voor montage | Voir aussi les instructions générales pour montage | Siehe auch allgemeine Instruktionen für Montage | Ver instrucciones generales para montaje | Vedi anche le istruzioni generali per il montaggio | Также смотрите общие инструкции по установке

**INSTALLATION INSTRUCTIONS
COVER SKIRTING**

ONLY FULL GUARANTEE WITH DECOFIX
VOLLEDIGE GARANTIE ENKEL BIJ GEBRUIK VAN DECOFIX
GARANTIE TOTALE UNIQUEMENT AVEC COLLE DECOFIX
VOLLSTÄNDIGE GARANTIE NUR BEI DER VERWENDUNG VON DECOFIX
GARANTÍA COMPLETA SÓLO SI SE UTILIZA DECOFIX
GARANZIA COMPLETA SOLO CON DECOFIX
ГАРАНТИЯ НА ПРОДУКЦИЮ ДЕЙСТВУЕТ ТОЛЬКО ПРИ ИСПОЛЬЗОВАНИИ КЛЕЯ DECOFIX

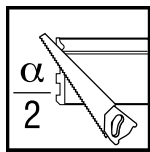
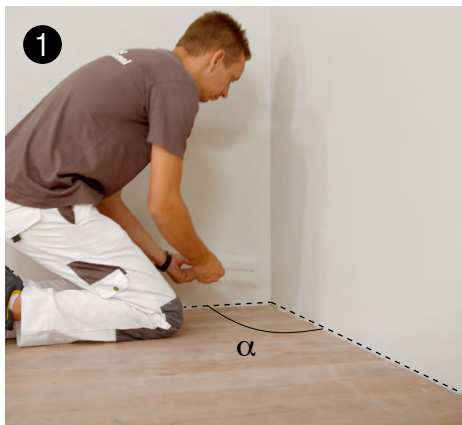
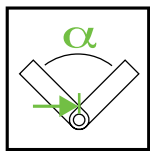

2a **Inside corner** | Binnenhoek | Coin intérieur | Innenecke | Esquina interna | Angulo interno | Внутренний угол

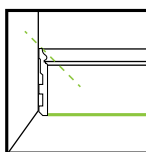
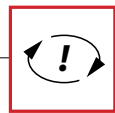
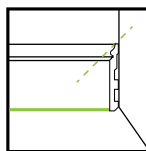

2b **Outside corner** | Buitenhoek | Coin extérieur | Aussenecke | Esquina externa | Angulo externo | Внешний угол

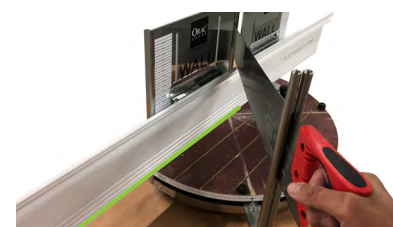
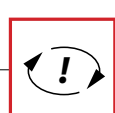
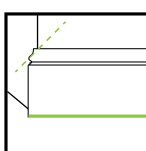
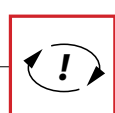
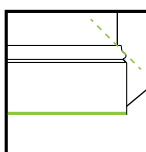

INSTALLATION INSTRUCTIONS COVER SKIRTING

3

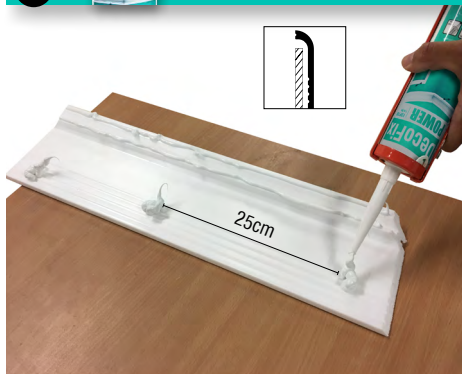

Apply DecoFix Power on the gluing surfaces. If the gap between the new and old skirting is large, apply thick dabs | Breng DecoFix Power aan op de lijmvlakken. Als de ruimte tussen de nieuwe en oude plint groot is, breng dan dikke doten aan | Appliquez DecoFix Power sur les surfaces à coller. Si la distance entre la nouvelle et l'ancienne plinthe est grande, appliquez des touches épaisses | Tragen Sie DecoFix Power auf die Klebeflächen auf. Wenn der Spalt zwischen der neuen und der alten Sockelleiste groß ist, dick auftragen | Aplicar DecoFix Power sobre las superficies de encolado. Si la separación entre el rodapié nuevo y el viejo es grande, aplique puntos gruesos | Applicare DecoFix Power sulle superfici di incollaggio. Se lo spazio tra il nuovo e il vecchio battiscopa è ampio, applicare punti spessi | Нанесите DecoFix Power на склеиваемые поверхности. Если зазор между новым и старым плинтусом большой, нанесите толстыми точками

4

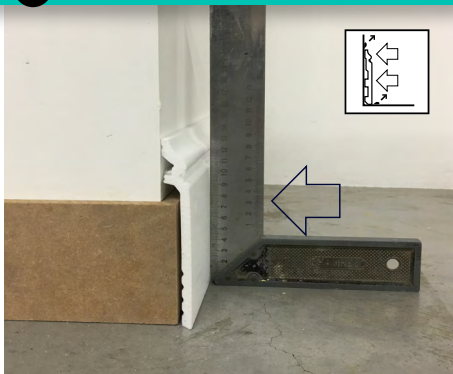

Push firmly | Duw stevig aan | Pressez fermement | Fest andrücken | Presione bien | Premere con forza | Плотно прижмите

5

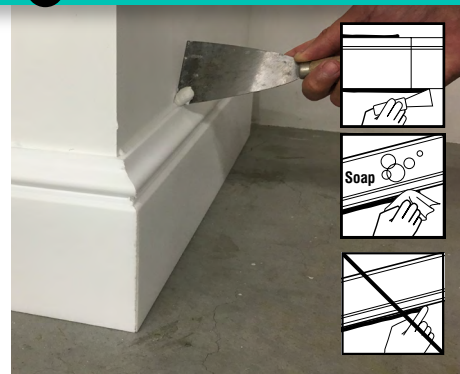

DecoFix Power: remove with soap solution | Verwijder met zeepoplossing | Éliminer avec solution savonneuse | Entfernen mit Seifenlösung | Eliminar con agua y jabón | Rimuovere con acqua e sapone | мыльный раствор

6



Use DecoFix Ultra in every joint | Gebruik DecoFix Ultra in elke naad | Utilisez DecoFix Ultra pour chaque joint | Verwenden Sie DecoFix Ultra bei jeder Naht | Utilice DecoFix Ultra en todas las juntas | Utilizzare DecoFix Ultra su tutti i giunti | Используйте DecoFix Ultra для всех стыков

7



Push firmly | Duw stevig naar elkaar toe | Poussez fermement | Fest aneinander drücken | Presione con firmeza | Premere con forza | Плотно прижмите

8

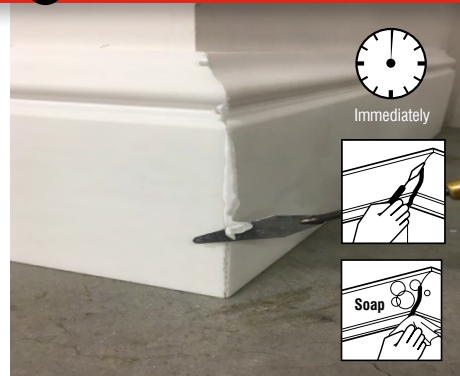

Clean excess adhesive with a painter's knife and soapy water within 10 min. after application | Reinig overtollige lijm met een schildersmesje en zeepwater binnen 10 minuten na het aanbrengen | Nettoyez l'excédent d'adhésif à l'eau savonneuse dans les 10min après l'application | Überschüssigen Klebstoff innerhalb von 10 Minuten nach dem Auftragen mit einem Malmesser und Seifenlauge entfernen | Limpiar el exceso de adhesivo con una espátula y agua jabonosa en los 10 min siguientes a la aplicación | Rimuovere l'adesivo in eccesso con un coltello da pittura e acqua saponata per l'indurimento | Плотно прижмите профили друг к другу и удалите излишки клея до его застывания с помощью малярного ножа и мыльного раствора.

9

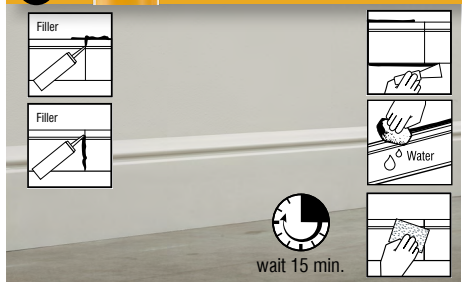

Use DecoFiller to smooth out the visible joints | Gebruik DecoFiller om de zichtbaarheid van de naden te verminderen | Utilisez DecoFiller pour dissimuler les joints visibles | Verwenden Sie DecoFiller um die Stoßstellen zu spachteln | Use DecoFiller para disimular las juntas | Utilizzare DecoFiller per isciare le giunzioni visibili | Используйте DecoFiller, чтобы сгладить видимые стыки

10



Can be painted after 30 minutes | Kan na 30 minuten geschilderd worden | Peut être peint après 30 minutes | Kann nach 30 Minuten überstrichen werden | Se puede pintar después de 30 minutos | Può essere verniciato dopo 30 minuti | Можно окрашивать через 30 минут